



PARTS & ACCESSORIES CATALOGUE 2015



ASNU Corporation Europe Ltd

Phone +44 (0) 208 420 4494 Fax +44 (0) 208 420 4495

e-mail: asnu.sales@asnu.com web site: www.asnu.com

TABLE OF CONTENTS

General Index - Fuel Injectors & Testing Adapters	Pages 2-9
Specialized Guide - Top Feed Injectors	Pages 10-43
Specialized Guide - Side Feed Injectors	Pages 44-54
Gasoline Direct Injectors (Gdi)	Pages 55-65
Piezo Injectors	Pages 66-67
Asnu Machine - Adapters, Spares & Accessories	Pages 68-84
Warranty Disclaimer	Page 85

FUEL INJECTOR INDEX

ADAPTERS & COMPONENTS

IMPORTANT

MANY INJECTORS LOOK ALIKE. THE ILLUSTRATIONS SHOWN IN THIS CATALOG ARE THE BEST POSSIBLE REPRESENTATIONS & SHOULD BE USED ONLY AS A GUIDE. PRIOR TO SELECTING INJECTOR COMPONENTS, & BEFORE DISASSEMBLING, ALWAYS INSPECT THE INJECTOR TO BE SERVICED. THEN CAREFULLY MATCH & SELECT THE COMPONENTS WITH THE ILLUSTRATIONS.

FOR TECHNICAL ASSISTANCE, PLEASE SEND A FAX TO: +44 (0) 208 420 4495

or email: asnu.sales@asnu.com



BOSCH TYPE
EV1.3 BODY
PAGE 10



GM MULTI-PORT
MULTEC
PAGE 11



BOSCH K-JET
MECHANICAL
PAGE 12



HONDA
KEIHIN STYLE
PAGE 13



BOSCH D-JET
EV1.0 BODY
PAGE 14



BOSCH D-JET
EV1.0 BODY
PAGE 15



BOSCH CHIMNEY
STYLE PINTLE CAP
PAGE 16

FUEL INJECTOR INDEX

ADAPTERS & COMPONENTS



BOSCH EV1.0
FORD/MAZDA
PAGE 17



BOSCH EV1.0
MAZDA
PAGE 18



BOSCH EV1.0
TOYOTA/MAZDA
PAGE 19



BOSCH EV1.0
MITSUBISHI/MAZDA
PAGE 20



DENSO FORD /
MAZDA / KIA
PAGE 21



LUCAS
PAGE 22



SAGEM
PAGE 23



SIEMENS
PAGE 24



WEBER MPI
PAGE 25



DELPHI MPI
PAGE 26



DELPHI MPI
PAGE 27



BOSCH EV6
PAGE 28

FUEL INJECTOR INDEX

ADAPTERS & COMPONENTS



BOSCH EV6
PAGE 29



BOSCH EV6
PAGE 30



BOSCH
PAGE 31



ASRAM TOYOTA
PAGE 32



DENSO LEXUS
PAGE 33



TOYOTA MULTIPOINT
PAGE 34



HONDA KEIHIN
PAGES 35



HONDA KEIHIN
PAGE 36



DENSO
PAGE 37



WEBER MULTIPOINT
PAGE 38



SAGEM
PAGE 39



TOYOTA SUZUKI
PAGE 39

FUEL INJECTOR INDEX

ADAPTERS & COMPONENTS



TOYOTA SUZUKI
MULTIPOINT
PAGE 40



SUZUKI MULTIPOINT
PAGE 41



MITSUBISHI
MULTIPOINT
PAGE 42



TOYOTA MULTIPOINT
PAGE 43



JECS TYPE TOYOTA
PAGE 44



JECS TYPE NISSAN
PAGE 45



NISSAN SUBARU SPI
PAGE 46



GM TBI MAXI
PAGE 47



GMI TBI 700 MULTEC
DELPHI / ROCHESTER
DAEWOO - PAGE 48



MAGNETI MARELLI
WEBER
PAGE 49



NISSAN NAVARRA /
PATHFINDER
PAGE 50



MAZDA / FORD /
DENSO
PAGE 51

FUEL INJECTOR INDEX

ADAPTERS & COMPONENTS



CHRYSLER TBI BOSCH
PAGE 52



MAZDA FORD
SIEMENS
PAGE 53



NISSAN MICRA
PAGE 54



mitsubishi hitachi -
GDI
PAGE 55



CITREON / PEUGOT
GDI - SIEMENS
PAGE 56



FORD GDI - BOSCH
PAGE 57



VW - GDI BOSCH
PAGE 58



VW - GDI BOSCH
PAGE 59



BMW - GDI
BOSCH
PAGE 60



DENSO GDI
PAGE 61



DELPHI GDI
FOR GM/HYUNDAI/KIA
PAGE 62



OPTIMAX - MERCURY
MARINE ENGINE
PAGE 63

FUEL INJECTOR INDEX

ADAPTERS & COMPONENTS



FITCH INJECTOR KIT
PAGE 64



E-TEC INJECTOR KIT
PAGE 64



BMW GDI (B38)
PAGE 65



PIEZO INJECTOR
SIEMENS
PAGE 66



PIEZO INJECTOR
BOSCH
PAGE 67

ADAPTERS & COMPONENTS

IMPORTANT - INJECTOR SERVICE INFORMATION

- **QUALIFY THE INJECTORS TO BE SERVICED.**
- **CORROSION & RUST IN INJECTOR INLET CANNOT BE PROPERLY CLEANED.**
- **INJECTORS WITH BROKEN OR DAMAGED PINTLE CANNOT BE REPAIRED.**
- **BEFORE DISASSEMBLING THE INJECTOR, MAKE SURE YOU HAVE THE NECESSARY REPAIR COMPONENTS. SOME INJECTOR COMPONENTS CANNOT BE REPLACED OR NOT AVAILABLE FROM ASNU. REFER TO THE INJECTOR INDEX.**
- **ADAPTER APPLICATIONS: REFER TO PAGES TO THE INJECTOR INDEX.**
- **ACCESSORY INFORMATION: REFER TO PAGES 62-74.**
- **FOR BEST PERFORMANCE, CLEANED INJECTORS SHOULD BE INSTALLED IN VEHICLE IMMEDIATELY AFTER SERVICING WITH ASNU.**
- **SHELF LIFE: SERVICED INJECTORS THAT WILL NOT BE RE-INSTALLED TO A VEHICLE ENGINE MUST BE TREATED WITH LIQUID PARRAFIN OR LIGHT OIL TO PREVENT SEIZING OF INTERNAL COMPONENTS. REFER TO ASNU OPERATION MANUAL FOR PROPER PROCEDURE.**
- **RED PROTECTIVE CAPS MUST BE INSTALLED TO PREVENT CONTAMINATION & PRESERVE INJECTOR SHELF LIFE. SEE INJECTOR INDEX TO SELECT PROPER PROTECTIVE CAPS.**
- **TECHNICAL ASSISTANCE: asnu.sales@asnu.com**

EMAIL: asnu.sales@asnu.com

IMPORTANT

MANY INJECTORS LOOK ALIKE. THE ILLUSTRATIONS SHOWN IN THIS CATALOG ARE THE BEST POSSIBLE REPRESENTATIONS & SHOULD BE USED ONLY AS A GUIDE. PRIOR TO SELECTING INJECTOR COMPONENTS, & BEFORE DISASSEMBLING, ALWAYS INSPECT THE INJECTOR TO BE SERVICED. THEN CAREFULLY MATCH & SELECT THE COMPONENTS WITH THE ILLUSTRATIONS. FOR TECHNICAL ASSISTANCE, PLEASE CALL: +44 (0) 208 420 4494 OR EMAIL: asnu.sales@asnu.com

TOP FEED INJECTORS

 <p>Use Test Adapter ASNU57 with filter in</p> <p>Connect Injectors with ASNU70 Harness</p> <p>BOSCH TYPE EV1.3 Body</p>	 <p>ASNU03 FILTER</p>	 <p>ASNU08 O-RING</p>	 <p>ASNU27 PINTLE CAP (BMW) YELLOW</p>	
	 <p>ASNU36 BMW CAP (3MM HOLE) YELLOW</p>	 <p>ASNU26 PINTLE CAP YELLOW</p>	 <p>ASNU35 TWIN HOLE PINTLE CAP YELLOW</p>	 <p>ASNU29 PINTLE CAP YELLOW</p>
	 <p>ASNU13 BOSCH VW 3MM HOLE GREEN</p>	 <p>ASNU09 YELLOW WASHER</p>	 <p>ASNU33 CLIP</p>	 <p>ASNU25 CAP (2 REQ)</p>
	 <p>Adapter ASNU57 tests injectors with filter installed</p>		 <p>ASNU70 UNIVERSAL HARNESS</p>	







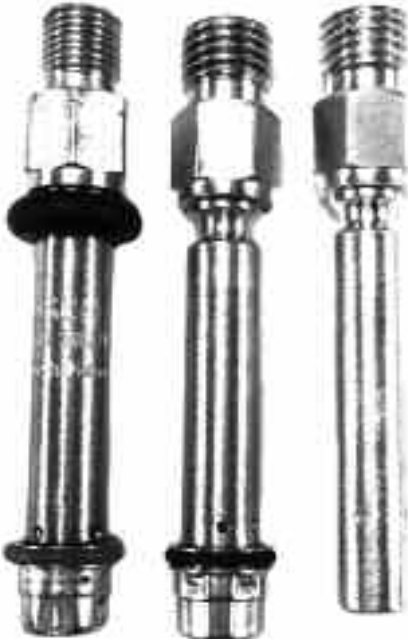

NOTES:

TOP FEED INJECTORS

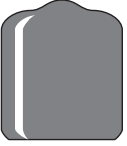
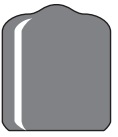
 <p>Use Test Adapter ASNU57 with filter in</p> <p>Connect Injectors with ASNU70 Harness</p> <p>GM MULTI-PORT MULTEC INJECTOR</p>	 <p>ASNU03 FILTER</p>	 <p>ASNU14 O-RING (2 REQ)</p>
	 <p>ASNU25 CAP (2 REQ)</p>	 <p>ASNU255 SPACER</p>
	 <p>Adapter ASNU57 tests injectors with filter installed</p>	 <p>ASNU70 UNIVERSAL HARNESS</p>

NOTES:

TOP FEED INJECTORS

 <p>Use Adapter ASNU50 or ASNU54 or ASNU55</p> <p>BOSCH MECHANICAL FUEL INJECTOR K-JETRONIC & COLD START VALVES</p>	 <p>ASNU12 O-RING</p>	 <p>ASNU225 O-RING AUDI APPLICATIONS</p>	
	 <p>ASNU25 CAP</p>	 <p>ASNU24 CAP</p>	
	 <p>ASNU227 MOUNT SEAL - VARIOUS</p>	 <p>ASNU228 BOOT - SOME BMW</p>	
	 <p>Adapter ASNU50 10MM Female Coupling For Male K-Jet & Cold Start</p>	 <p>Adapter ASNU54 8MM Male Coupling for Female K-Jet & Cold Start</p>	 <p>Adapter ASNU55 12MM Female Coupling for Male K-Jet</p>

NOTES:

TOP FEED INJECTORS

 <p>Use Test Adapter ASNU59 with filter in</p> <p>Connect Injectors with ASNU70 Harness</p> <p>HONDA MULTI-PORT KEIHIN STYLE</p>	 <p>ASNU30B O-RING</p>	 <p>ASNU30 O-RING</p>	 <p>ASNU30C INSULATOR</p>
	<p>PINTLE CAP CANNOT BE REPLACED.</p> <p>DO NOT REMOVE FOR INJECTOR CLEANING NOR TESTING</p>		 <p>ASNU30A GROMMET</p>
	 <p>ASNU30F FILTER</p>	 <p>ASNU25 CAP</p>	 <p>ASNU24 CAP</p>
	 <p>Adapter ASNU59 tests injectors with filter installed</p>	 <p>ASNU70 UNIVERSAL HARNESS</p>	











NOTES:

TOP FEED INJECTORS

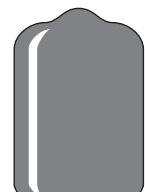
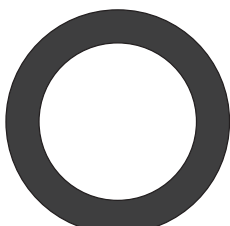
 <p>Use Adapter ASNU58 with hose installed</p> <p>Connect Injectors with ASNU70 Harness</p> <p>MERCEDES / JAGUAR / VOLVO WITH BOSCH D-JETRONIC EV1.0 BODY</p>	 <p>ASNU07 PINTLE CAP</p>	 <p>ASNU03 FILTER</p>	
	 <p>ASNU16 O-RING</p>	 <p>ASNU24 CAP</p>	
	 <p>ASNU11 SEAL</p>	 <p>ASNU25 CAP</p>	 <p>ASNU34 FERRULE</p>
	 <p>Adapter ASNU58 tests injectors w/hose & filter installed</p>	 <p>Adapter ASNU51 tests injectors with filter removed</p>	 <p>ASNU70 UNIVERSAL HARNESS</p>

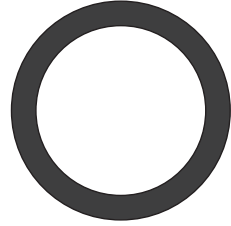
NOTES:

TOP FEED INJECTORS

 <p>Use Adapter ASNU58 with hose installed</p> <p>Connect Injectors with ASNU70 Harness</p> <p>GM / JAGUAR / FIAT / ALFA WITH BOSCH D-JETRONIC European Applications</p>	 <p>ASNU07 PINTLE CAP</p>	 <p>ASNU16 O-RING</p>		
	 <p>ASNU03 FILTER</p>	 <p>ASNU24 CAP</p>	 <p>ASNU25 CAP</p>	
	 <p>ASNU11 SEAL</p>	 <p>ASNU34 FERRULE</p>	 <p>ASNU19 SEAL</p>	
	 <p>Adapter ASNU58 tests injectors w/hose & filter installed</p>	 <p>Adapter ASNU51 tests injectors with filter removed</p>	 <p>ASNU70 UNIVERSAL HARNESS</p>	

NOTES:

TOP FEED INJECTORS

 <p>BOSCH CHIMNEY STYLE PINTLE CAP</p>	 <p>ASNU09 WASHER</p>	 <p>ASNU08 O-RING</p>	 <p>ASNU28 PLASTIC PINTLE CAP</p>
	 <p>ASNU03 FILTER</p>	 <p>ASNU33 CLIP</p>	
	 <p>ASNU25 CAP</p>	 <p>ASNU24 CAP</p>	
	 <p>Adapter ASNU57 tests injectors with filter installed</p>	 <p>ASNU70 UNIVERSAL HARNESS</p>	

NOTES:

TOP FEED INJECTORS

 <p>Use Test Adapter ASNU59 with filter in</p> <p>Connect Injectors with ASNU70 Harness</p> <p>BOSCH EV1.0 BODY Ford / Mazda Applications</p>	 <p>ASNU07 PINTLE CAP</p>	 <p>ASNU275 PINTLE CAP</p>	 <p>ASNU278 PINTLE CAP</p>	 <p>ASNU279 PINTLE CAP</p>	 <p>ASNU38 PINTLE CAP</p>
	 <p>ASNU280 PINTLE CAP</p>	 <p>ASNU03 FILTER</p>	 <p>ASNU24 CAP</p>	 <p>ASNU25 CAP</p>	 <p>ASNU15 BUSHING</p>
	 <p>ASNU17 O-RING</p>	 <p>ASNU224 O-RING</p>	 <p>ASNU228 BLEEDER O-RING</p>	 <p>ASNU229 O-RING</p>	
	 <p>Adapter ASNU59 tests injectors with filter installed</p>	 <p>ASNU70 UNIVERSAL HARNESS</p>			

NOTES:

TOP FEED INJECTORS



Use Test Adapter
ASNU59 with filter in

Connect Injectors with
ASNU70 Harness

BOSCH EV1.0 BODY
Mazda Applications



ASNU17
O-RING



ASNU15
UPPER BUSHING

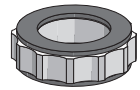

ASNU238
LOWER BUSHING
w/CERAMIC INSERT



ASNU07
PINTLE CAP



ASNU03
FILTER



ASNU24
CAP



ASNU25
CAP













Adapter ASNU59
tests injectors with
filter installed

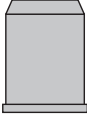

ASNU70
UNIVERSAL
HARNESS









NOTES:

TOP FEED INJECTORS

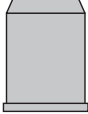
 <p>Use Test Adapter ASNU59 with filter in</p> <p>Connect Injectors with ASNU70 Harness</p> <p>BOSCH EV1.0 BODY Toyota/Mazda Applications</p>	 <p>ASNU17 O-RING</p>	 <p>ASNU18 SEAL</p>	 <p>ASNU15 BUSHING</p>	
	 <p>ASNU03 FILTER</p>	 <p>ASNU38B PINTLE CAP</p>	 <p>ASNU07 PINTLE CAP</p>	
	 <p>ASNU24 CAP</p>	 <p>ASNU25 CAP</p>		
	 <p>Adapter ASNU59 tests injectors with filter installed</p>	 <p>ASNU70 UNIVERSAL HARNESS</p>		











NOTES:

TOP FEED INJECTORS

 <p>Use Test Adapter ASNU59 with filter in</p> <p>Connect Injectors with ASNU70 Harness</p> <p>BOSCH EV1.0 BODY Chrysler Mitsubishi Mazda Toyota</p>	 <p>ASNU03 FILTER</p>	 <p>ASNU07 PINTLE CAP</p>	 <p>ASNU274 PINTLE CAP</p>	 <p>ASNU38B PINTLE CAP</p>
	 <p>ASNU17 O-RING</p>	 <p>ASNU15 BUSHING</p>	 <p>ASNU18 SEAL</p>	
	 <p>ASNU25 CAP</p>	 <p>ASNU24 CAP</p>		
	 <p>Adapter ASNU59 tests injectors with filter installed</p>	 <p>ASNU70 UNIVERSAL HARNESS</p>		

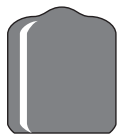
NOTES:

TOP FEED INJECTORS

 <p>Use Test Adapter ASNU59 with filter in</p> <p>Connect Injectors with ASNU70 Harness</p> <p>DENSO Ford / Mazda / Kia</p>	 <p>ASNU03 FILTER</p>		 <p>ASNU07 PINTLE CAP</p>	
	 <p>ASNU17 O-RING</p>	 <p>ASNU15 BUSHING</p>		 <p>ASNU18 SEAL</p>
	 <p>ASNU25 CAP</p>		 <p>ASNU24 CAP</p>	
	 <p>Adapter ASNU59 tests injectors with filter installed</p>		 <p>ASNU70 UNIVERSAL HARNESS</p>	

NOTES:

TOP FEED INJECTORS

 <p>Use only ASNU02 Filter ↓</p> <p>Use Test Adapter ASNU57 with filter in</p> <p>Connect Injectors with ASNU70 Harness</p> <p>LUCAS DISC INJECTOR</p>	 <p>ASNU08 O-RING (Lower)</p>	 <p>ASNU08B O-RING (Upper) (Buna-Black)</p>
	 <p>ASNU02 FILTER</p>	 <p>ASNU25 CAP</p>
	 <p>Adapter ASNU57 tests injectors with filter installed</p>	 <p>ASNU70 UNIVERSAL HARNESS</p>

NOTES:

TOP FEED INJECTORS

 <p>LUCAS BMW AIR ASSISTED</p>	 <p>ASNU14 TOP O-RING Retainer should not be removed</p>	 <p>ASNU21 BOTTOM O-RING</p>	 <p>ASNU03 FILTER</p>
	 <p>ASNU89 ADAPTER PLATE (USE TO HOLD BOTTOM OF INJECTORS IN TEST RAIL)</p>		
	 <p>Adapter ASNU57 tests injectors with filter installed</p>	 <p>ASNU70 UNIVERSAL HARNESS</p>	

NOTES:

TOP FEED INJECTORS



SIEMENS DEKA



ASNU14
TOP O-RING
Retainer should
not be removed



ASNU03
FILTER



ASNU89
ADAPTER PLATE
(USE TO HOLD BOTTOM OF INJECTORS IN TEST RAIL)



Adapter ASNU57
tests injectors with
filter installed



ASNU70
UNIVERSAL
HARNESS

NOTES:

DO NOT PULSE SIEMENS DEKA INJECTORS DURING CLEANING

TOP FEED INJECTORS



Use Test Adapter
ASNU57 with filter in

Connect Injectors with
ASNU70 Harness

WEBER MPI



ASNU04
FILTER
w/wider crush ring



ASNU05
PINTLE CAP



ASNU09
SPACER



ASNU08
O-RING



ASNU24
CAP



ASNU25
CAP











Adapter ASNU57
tests injectors with
filter installed



ASNU70
UNIVERSAL
HARNESS









NOTES:

TOP FEED INJECTORS

 <p>Use Test Adapter ASNU57 Use custom harness ASNU116</p> <p>DELPHI MULTEC MULTIPOINT</p>	 <p>ASNU239 O-RING (LOWER)</p>	 <p>ASNU14 O-RING (UPPER)</p>	 <p>ASNU03 FILTER</p>
	 <p>ASNU89 ADAPTER PLATE (USE TO HOLD BOTTOM OF INJECTORS IN TEST RAIL)</p>		
	 <p>ASNU254 PINTLE CAP BLACK</p>		
	 <p>ADAPTER ASNU57 (Tests injectors with filter installed)</p>	 <p>CUSTOM HARNESS ASNU116 (Tests up to 8 injectors)</p>	







NOTES:

TOP FEED INJECTORS

 <p>Use Test Adapter ASNU44 Use custom harness ASNU116</p> <p>DELPHI MULTEC MULTIPOINT</p>	 <p>ASNU239 O-RING (LOWER)</p>	 <p>ASNU14 O-RING (UPPER)</p>	 <p>ASNU03 FILTER</p>
	 <p>ASNU89 ADAPTER PLATE (USE TO HOLD BOTTOM OF INJECTORS IN TEST RAIL)</p>		
	 <p>ASNU254 PINTLE CAP BLACK</p>		
	 <p>Adapter ASNU44 Extra Long Adapter tests injectors with filter installed</p>	 <p>CUSTOM HARNESS ASNU116 (Tests up to 8 injectors)</p>	







NOTES:

TOP FEED INJECTORS

 <p>Use Test Adapter ASNU57 with filter in</p> <p>BOSCH EV6 MULTIPOINT</p>	 <p>ASNU14 O-RING (2 Req.)</p>	 <p>ASNU03 FILTER</p>	 <p>ASNU192 PINTLE CAP</p>
	 <p>ASNU89 ADAPTER PLATE (USE TO HOLD BOTTOM OF INJECTORS IN TEST RAIL)</p>		
	 <p>ADAPTER ASNU57 tests injectors with filter installed</p>	 <p>ASNU70 UNIVERSAL HARNESS</p>	







NOTES:

TOP FEED INJECTORS

 <p>Use Test Adapter ASNU57 with filter in</p> <p>BOSCH EV6 MULTIPOINT</p>	 <p>ASNU14 O-RING (2 Req.)</p>	 <p>ASNU191 PINTLE CAP Short Chimney Style (Orange)</p>	 <p>ASNU03 FILTER</p>
	 <p>ASNU89 ADAPTER PLATE (USE TO HOLD BOTTOM OF INJECTORS IN TEST RAIL)</p>		
	 <p>ADAPTER ASNU57 tests injectors with filter installed</p>	 <p>ASNU70 UNIVERSAL HARNESS</p>	

NOTES:

TOP FEED INJECTORS

 <p>Use Test Adapter ASNU57 with filter in</p> <p>BOSCH EV6 MULTIPORT</p>	 <p>ASNU14 O-RING (2 Req.)</p>	 <p>ASNU190 PINTLE CAP Flat Washer Style (Orange)</p>	 <p>ASNU03 FILTER</p>
	 <p>ASNU89 ADAPTER PLATE (USE TO HOLD BOTTOM OF INJECTORS IN TEST RAIL)</p>		
	 <p>ADAPTER ASNU57 Tests injectors with filter installed</p>	 <p>ASNU70 UNIVERSAL HARNESS</p>	

NOTES:

TOP FEED INJECTORS

 <p>Use Test Adapter ASNU44 with filter in</p> <p>BOSCH EV14 MULTIPOINT</p>	 <p>ASNU14 TOP O-RING Retainer should not be removed</p>	<p>INTERNAL FILTER NOT REPLACEABLE</p>
	 <p>ASNU89 ADAPTER PLATE (USE TO HOLD BOTTOM OF INJECTORS IN TEST RAIL)</p>	 <p>ASNU247 LOWER O-RING</p>
	 <p>ADAPTER ASNU44 Tests injectors with filter installed</p>	 <p>ASNU70 UNIVERSAL HARNESS</p>









NOTES:

TOP FEED INJECTORS

 <p>← Do Not Remove pintle cap</p> <p>Use Test Adapter ASNU59 with filter in</p> <p>Connect Injectors with ASNU70 Harness</p> <p>ASRAM - TOYOTA - LEXUS PRADO / 4-RUNNER / GX LAND CRUISER (EUROPE)</p>	 <p>ASNU17 O-RING (2 REQ)</p>	 <p>ASNU03 FILTER</p>
	 <p>ASNU242 INSULATOR</p>	 <p>ASNU289 PINTLE CAP</p>
	 <p>ADAPTER ASNU59 Tests injectors with filter installed</p>	 <p>ASNU70 UNIVERSAL HARNESS</p>

NOTES:

TOP FEED INJECTORS

 <p>Use Test Adapter ASNU59 with filter in</p> <p>Connect Injectors with ASNU70 Harness</p> <p>DENSO - LEXUS ES / GS</p>	 <p>ASNU17 O-RING (2 REQ)</p>	 <p>ASNU03 FILTER</p>
	 <p>ASNU242 INSULATOR</p>	 <p>ASNU15 BUSHING</p>
	 <p>ASNU289 TWIN HOLE PINTLE CAP</p>	
	 <p>ADAPTER ASNU59 Tests injectors with filter installed</p>	 <p>ASNU70 UNIVERSAL HARNESS</p>

NOTES:

TOP FEED INJECTORS



Use Test Adapter
ASNU45 with filter in

Connect injectors with
ASNU70 Harness

TOYOTA COROLLA / YARIS /
NEW SENSATION / CELICA /
TERIOS

TOYOTA MULTIPORT



ASNU245
TOP O-RING



ASNU08C
LOWER O-RING



ASNU02A
FILTER



ASNU89
ADAPTER PLATE
(USE TO HOLD BOTTOM OF INJECTORS IN TEST RAIL)









ADAPTER ASNU45
Tests injectors with
filter installed



ASNU70
UNIVERSAL
HARNESS

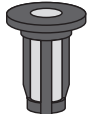



NOTES:

TOP FEED INJECTORS

 <p>← Pintle Cap under development</p> <p>Use Test Adapter ASNU44 with filter in</p> <p>HONDA KEIHIN MULTIPORT</p>	 <p>ASNU14 O-RING (2 Req.)</p>	 <p>ASNU02 FILTER</p>
	 <p>ASNU89 ADAPTER PLATE (USE TO HOLD BOTTOM OF INJECTORS IN TEST RAIL)</p>	
	 <p>ADAPTER ASNU44 Extra Long Adaptor tests injectors with filter installed</p>	 <p>ASNU70 UNIVERSAL HARNESS</p>
		 <p>ASNU90/HA012 Harness Adaptor (required with the ASNU70 for Suzuki motorbike injectors)</p>

NOTES:

TOP FEED INJECTORS

 <p>← Lower O-Ring under development</p>	 <p>ASNU14 O-RING (Qty 2)</p>	 <p>LOWER O-RING - UNDER DEVELOPMENT</p>	 <p>ASNU03 FILTER</p>
	 <p>ASNU89 ADAPTER PLATE (USE TO HOLD BOTTOM OF INJECTORS IN TEST RAIL)</p>		
<p>Use Test Adapter ASNU57 with filter in</p> <p>HONDA KEIHIN CIVIC SI CRV</p>	 <p>ADAPTER ASNU57 Tests injectors with filter installed</p>	 <p>ASNU70 UNIVERSAL HARNESS</p>	

NOTES:

TOP FEED INJECTORS



Use Test Adapter
ASNU59 with filter in

Connect injectors with
ASNU70 Harness

TOYOTA COROLLA / YARIS /
NEW SENSATION / CELICA /
TERIOS

TOYOTA MULTIPORT



ASNU17
O-RING



ASNU18
SEAL



ASNU 290 DENSO
INJECTOR BLACK
PINTLE CAP -
5mm SHORT
SMALL HOLE



ASNU 292 DENSO
INJECTOR BLACK
PINTLE CAP -
10mm LONG



ASNU 291
DENSO INJECTOR
BLACK PINTLE
CAP - 5mm
SHORT LARGE
HOLE



ADAPTER ASNU59
Tests injectors with
filter installed



ASNU70
UNIVERSAL
HARNESS

NOTES:

TOP FEED INJECTORS



Use Test Adapter
ASNU44 with filter in

Connect Injectors with
ASNU70 Harness

FIAT / PALIO / SIENNA / UNO
RENAULT MEGANE
SEAT CORDOVA - VW GOLF

WEBER MULTIPOINT



ASNU14
O-RING (2 Req.)



ASNU04
FILTER
w/wider crush ring



ASNU89
ADAPTER PLATE
(USE TO HOLD BOTTOM OF INJECTORS IN TEST RAIL)



ADAPTER ASNU44
Tests injectors with
filter installed



ASNU70
UNIVERSAL
HARNESS

NOTES:

TOP FEED INJECTORS

REPLACE THIS INJECTOR
WITH
BOSCH REPLACEMENT - 0280 156 025



NOT SERVICEABLE

SAGEM MINI
CITROEN / PEUGEOT / RENAULT



BOSCH REPLACEMENT - 0280 156 025

NOTES:

TOP FEED INJECTORS



Use Test Adapter
ASNU59 with filter in

Connect Injectors with
ASNU70 Harness

TOYOTA AUTANA / COROLLA /
CAMRY / CELICA
MITSUBISHI MONTERO
SUZUKI GRAN VITARA V6

TOYOTA SUZUKI MULTIPOINT



ASNU17
O-RING (2 REQ)



ASNU03
FILTER



ASNU18
GROMMET



ASNU15
BUSHING



ADAPTER ASNU59
Tests injectors with
filter installed



ASNU70
UNIVERSAL
HARNESS

NOTES:

TOP FEED INJECTORS

 <p>Use Test Adapter ASNU59 with filter in</p> <p>Connect Injectors with ASNU70 Harness</p> <p>SUZUKI GRAND VITARA</p> <p>SUZUKI MULTIPOINT</p>	 <p>ASNU17 O-RING</p>	 <p>ASNU03 FILTER</p>
	 <p>ASNU18 LOWER SEAL</p>	 <p>ASNU 659 UPPER SEAL</p>
	 <p>ADAPTER ASNU59 Tests injectors with filter installed</p>	 <p>ASNU70 UNIVERSAL HARNESS</p>

NOTES:

TOP FEED INJECTORS

 <p>Use Test Adapter ASNU59 with filter in</p> <p>Connect Injectors with ASNU70 Harness</p> <p>MITSUBISHI LANSER / SPACE / WAGON / MX / MF / GALANT</p> <p>MITSUBISHI MULTIPOINT</p>	 <p>ASNU245</p>	 <p>ASNU03 FILTER</p>	
	 <p>ASNU18 SEAL</p>	 <p>ASNU16 SEAL (either is required for various applications)</p>	 <p>ASNU15 BUSHING</p>
	 <p>ADAPTER ASNU59 Tests injectors with filter installed</p>	 <p>ASNU70 UNIVERSAL HARNESS</p>	

NOTES:

TOP FEED INJECTORS



ASNU17
O-RING



ASNU18
SEAL



ASNU03
FILTER

Use Test Adapter
ASNU59 with filter in

Connect injectors with
ASNU70 Harness

TOYOTA COROLLA / YARIS /
NEW SENSATION / CELICA /
TERIOS

TOYOTA MULTIPORT



ADAPTER ASNU59
Tests injectors with
filter installed



ASNU70
UNIVERSAL
HARNESS

NOTES:

SIDE FEED INJECTORS



← Re-use old filter



ASNU104C
O-RING



ASNU104B
O-RING



ASNU104A
O-RING

REPLACEMENT
FILTER CURRENTLY
NOT AVAILABLE
REUSE OLD
FILTER.

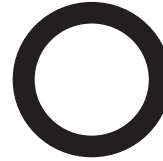

ASNU104D
INSULATOR

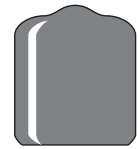

ASNU24
CAP

Use Test Adapter ASNU104
(block holds 6 injectors)

Connect Injectors with
ASNU70 Harness

JECS TYPE
TOYOTA



ASNU104
ADAPTER BLOCK



ASNU70
UNIVERSAL HARNESS

NOTES:

SIDE FEED INJECTORS



Use Test Adapter ASNU103
(block holds 6 injectors,
blanking off plugs available
for 4 cylinder models)

Connect Injectors with
ASNU70 Harness

J ECS TYPE
NISSAN



ASNU103B
LOWER O-RING



ASNU24
CAP



ASNU103A
UPPER O-RING



ASNU103C
FILTER



ASNU103E
PINTLE CAP

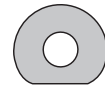

ASNU103H
SEAL



ASNU103
ADAPTER BLOCK

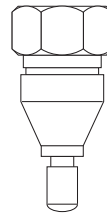

ASNU103X
BLANKING OFF
PLUG



ASNU70
UNIVERSAL
HARNESS

NOTES:

SIDE FEED INJECTORS



ASNU106C
Filter



ASNU07
Pintle Cap

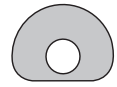

ASNU106E
Seal



ASNU106B
LOWER O-RING

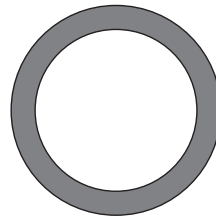

ASNU61A
UPPER O-RING

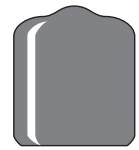

ASNU24
Cap

Use Test Adapter ASNU79
(single block)
Use Test Adapter ASNU75
(4 inj. block)
Use Adapter ASNU106
(6 inj. block)

Connect injectors with
ASNU70 Harness

Nissan / Subaru SPI



ASNU106
6 INJ. BLOCK

NOTES:

SIDE FEED INJECTORS



Use Test Adapter ASNU71
(single injector block includes
custom harness ASNU71H) or
Use Test Adapter ASNU101
(twin injector block includes
custom harness ASNU101H)

GM TBI MAXI



ASNU24
CAP

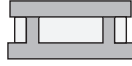

ASNU64F
FILTER



ASNU60J
DUST SEAL



ASNU60B
O-RING



ASNU71
SINGLE INJ. ADAPTER BLOCK

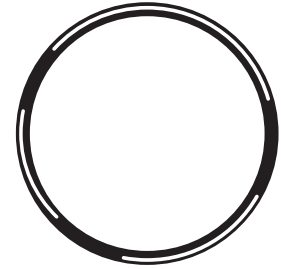

ASNU60E
O-RING

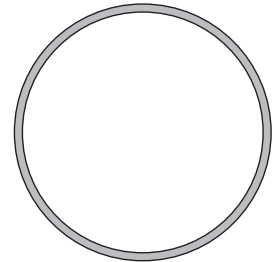

ASNU71F
WASHER



ASNU60F
SIDE FEED FILTER



ASNU101
TWIN INJ. ADAPTER BLOCK

NOTES:

SIDE FEED INJECTORS



Use Test Adapter ASNU72
(single injector block w/harness)

Use Test Adapter ASNU115
(4 injector block w/harness)

GM TBI 700 MULTEC
DELPHI / ROCHESTER
DAEWOO

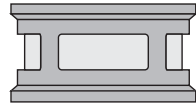

ASNU64E
FILTER (UPPER)

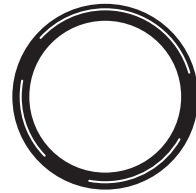

ASNU64A
O-RING, UPPER
(ROCHESTER)



ASNU64F
FILTER (LOWER)



ASNU60B
O-RING



ASNU24
CAP



ASNU72
ADAPTER BLOCK



ASNU115
4 INJ. ADAPTER BLOCK WITH
CUSTOM HARNESS ASNU115H

NOTES:

SIDE FEED INJECTORS



Use Test Adapter ASNU72
(single injector block w/harness)

Use Test Adapter ASNU115
(4 injector block w/harness)

MAGNETI MARELLI
WEBER

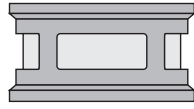

ASNU64C
FILTER (UPPER) - WEBER

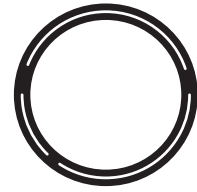

ASNU64A
O-RING UPPER



ASNU64D
FILTER (LOWER) - WEBER



ASNU60B
O-RING

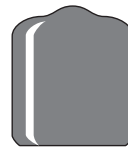

ASNU24
CAP









ASNU72
ADAPTER BLOCK

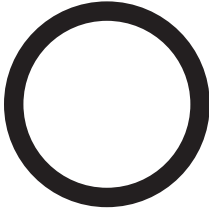

ASNU115
4 INJ. ADAPTER BLOCK WITH
CUSTOM HARNESS ASNU115H

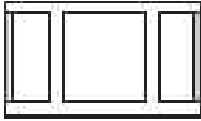
NOTES:

SIDE FEED INJECTORS

 <p>Use Test Adapter ASNU105 (block holds 4 injectors)</p> <p>Connect injectors with ASNU70 universal harness</p> <p>NISSAN NAVARA / PATHFINDER</p>	 <p>ASNU105A O-RING (UPPER)</p>	 <p>ASNU105B O-RING (LOWER)</p>
	 <p>ASNU105C FILTER</p>	 <p>ASNU25 CAP</p>
	 <p>ASNU105 ADAPTER BLOCK</p>	 <p>ASNU70 UNIVERSAL HARNESS</p>



NOTES:

SIDE FEED INJECTORS

 <p>Use Test Adapter ASNU78 (block holds 4 injectors Ford Zetec)</p> <p>or</p> <p>Test Adapter ASNU110 (block holds 6 injectors for Chrysler 3.5L)</p> <p>Connect injectors with ASNU70 universal harness</p> <p>MAZDA / FORD / DENSO</p>	 <p>ASNU62A O-RING (UPPER)</p>	 <p>ASNU14 O-RING (LOWER)</p>	 <p>ASNU78D FILTER DENSO</p>	
	 <p>ASNU70 UNIVERSAL HARNESS</p>	 <p>ASNU35 PINTLE CAP TWIN HOLE</p>	 <p>ASNU26 PINTLE CAP</p>	
	 <p>ASNU78 ADAPTER BLOCK (Holds 4 Injectors - Ford Zeta)</p>	 <p>ASNU110 ADAPTER BLOCK (Holds 6 Injectors - Chrysler 3.5L)</p>		

NOTES:

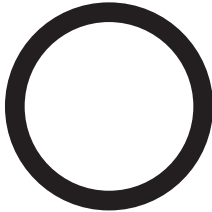
SIDE FEED INJECTORS

 <p>Use Test Adapter ASNU76 (single block includes custom harness)</p> <p>CHRYSLER TBI (BOSCH)</p>	 <p>ASNU65A O-RING (Upper)</p>	 <p>ASNU65B O-RING (Lower)</p>	 <p>ASNU24 Cap</p>	
	 <p>ASNU65F CLIP (UPPER)</p>	 <p>ASNU65C FILTER (UPPER)</p>	 <p>ASNU65D FILTER (LOWER)</p>	 <p>ASNU65E PINTLE CAP</p>
	 <p>ASNU76 ADAPTER BLOCK WITH CUSTOM HARNESS</p>			

NOTES:

SIDE FEED INJECTORS



Use Test Adapter ASNU78
(block holds 4 injectors
Ford Zetec)

or

Test Adapter ASNU110
(block holds 6 injectors for
Chrysler 3.5L)

Connect injectors with ASNU70
universal harness

MAZDA / FORD / SIEMENS

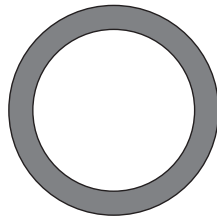

ASNU62A
O-RING
(UPPER)



ASNU14
O-RING
(LOWER)



ASNU78C
FILTER
SIEMENS



ASNU70
UNIVERSAL HARNESS



ASNU13
PINTLE CAP
3MM HOLE GREEN



ASNU26
PINTLE CAP



ASNU78
ADAPTER BLOCK
(Holds 4 Injectors -
Ford Zeta)



ASNU110
ADAPTER BLOCK
(Holds 6 Injectors -
Chrysler 3.5L / Jaguar)

NOTES:

SIDE FEED INJECTORS



ASNU112A
UPPER O-RING



ASNU112B
LOWER O-RING

REPLACEMENT FILTER IS UNDER
DEVELOPMENT & CURRENTLY
NOT AVAILABLE

RE-USE OLD FILTER

Use Test Adapter ASNU112
(4 Injector block)

Connect injectors with
ASNU70 universal harness

NISSAN MICRA



ASNU112
4 INJECTOR BLOCK



ASNU70
UNIVERSAL HARNESS

NOTES:

GASOLINE DIRECT INJECTION



Use Test Adapter ASNU 57
(with filter in)

MITSUBUSHI
HITACHI - GDI

For testing - remove top
O'Ring and replace with
ASNU 08 x 2 and use
ASNU 57 coupling.



ASNU 03
FILTER









INJECTOR ADAPTER
ASNU 57
Test injectors with
filter installed



WIRING HARNESS
ASNU 260
Universal Injector







NOTES:

GASOLINE DIRECT INJECTION

 <p>Use Test Adapter ASNU56 (with filter in)</p> <p>CITROEN / PEUGOT GDI - SIEMENS</p>	 <p>ASNU 262 O-RING (TOP)</p>	<p>Filter not available DO NOT REMOVE</p>
	 <p>ASNU 265 TEFLON SEALING BUSH</p>	 <p>ASNU 263 SPLIT SPACER</p>
	 <p>ASNU89 ADAPTER PLATE (USE TO HOLD BOTTOM OF INJECTORS IN TEST RAIL)</p>	
	 <p>INJECTOR ADAPTER ASNU 56 Test injectors with filter installed</p>	 <p>WIRING HARNESS ASNU 260 Universal Injector</p>







NOTES:

GASOLINE DIRECT INJECTION

	 <p>ASNU 265 TEFLON SEALING BUSH</p>	 <p>ASNU 03 FILTER</p>	 <p>ASNU259 TOP'O'RING 13mm</p>
	 <p>ASNU89 ADAPTER PLATE (USE TO HOLD BOTTOM OF INJECTORS IN TEST RAIL)</p>		
<p>Use Test Adapter ASNU 57 (with filter in)</p> <p>FORD - GDI BOSCH</p>	 <p>INJECTOR ADAPTER ASNU 57 Test injectors with filter installed</p>	 <p>WIRING HARNESS ASNU 260 Universal Injector</p>	

NOTES:

GASOLINE DIRECT INJECTION

 <p>Use Test Adapter ASNU268 with filter</p> <p>VW - GDI BOSCH</p>	 <p>ASNU 265 TEFLON SEALING BUSH</p>	 <p>ASNU 03 FILTER</p>	 <p>ASNU259 TOP 'O' RING 13mm</p>
	 <p>ASNU89 ADAPTER PLATE (USE TO HOLD BOTTOM OF INJECTORS IN TEST RAIL)</p>		
	 <p>INJECTOR ADAPTER ASNU 268 Test injectors with filter installed</p>	 <p>WIRING HARNESS ASNU 260 Universal Injector</p>	

NOTES:

GASOLINE DIRECT INJECTION

 <p>Use Test Adapter ASNU268 with filter</p> <p>VW - GDI BOSCH</p>	<p>WARNING, DO NOT REMOVE FILTER NOT REPLACEABLE</p>	 <p>ASNU 265 White 3mm Teflon Seal</p>
	 <p>ASNU259 TOP 'O' RING 13mm</p>	 <p>ASNU122 FUEL RAIL FOR GDI INJECTORS</p>
	 <p>INJECTOR ADAPTER ASNU 268 Test injectors with filter installed</p>	 <p>WIRING HARNESS ASNU 260 Universal Injector</p>

NOTES:

GASOLINE DIRECT INJECTION



BMW - GDI
BOSCH



ASNU 265A
Black 3.5mm Teflon Seal



INJECTOR ADAPTER
ASNU 123
Test injectors installed



INJECTOR HARNESS
ASNU 70P
Piezo Type Connectors



BOSCH RAIL
ASNU 180

NOTES:

GASOLINE DIRECT INJECTION

 <p>DENSO GDI</p>	 <p>ASNU 265 TEFLON SEALING BUSH</p>	 <p>ASNU 03 FILTER</p>
<p>TOP O’RING NOT YET AVAILABLE</p>		
 <p>INJECTOR ADAPTER ASNU 231 Test injectors with filter installed</p>	 <p>WIRING HARNESS ASNU 260 Universal Injector</p>	

NOTES:

GASOLINE DIRECT INJECTION



USE TEST ADAPTER ASNU258

Delphi GDI
For GM/Hyundai/Kia



ASNU 258
Adaptor



ASNU 03
Filter Basket



ASNU 265A
Black 3.5mm Teflon Seal
(2 required)



WIRING HARNESS
ASNU 260
Universal Injector

NOTES:

GASOLINE DIRECT INJECTION



OPTIMAX - MERCURY
MARINE ENGINE



ASNU 248
Service Kit



ASNU 68
INJECTOR ADAPTER COUPLING KIT

NOTES:

GASOLINE DIRECT INJECTION



Fitch Injector Kit
Part No: ASNU 246F



E-Tec Injector Kit
Part No: ASNU 246E

NOTES:



Fitch & E-Tec injectors only work in conjunction with the ASNU Marine GDI Injector Adaptor Box. Please contact us for more details.

GASOLINE DIRECT INJECTION



BMW GDI (B38)
Bosch



ASNU 132
Fuel Rail



ASNU 123BMW
Injector Adaptor



ASNU 265A
Black 3.5mm Teflon Seal



NOTES:

PIEZO INJECTORS



**SIEMENS
PIEZO GDI**
BMW
Gasoline Direct
Injection



ASNU120
FUEL RAIL FOR
SIEMENS PIEZO INJECTORS



ASNU 121
INJECTOR TO FUEL RAIL
COUPLING FOR
SIEMENS PIEZO INJECTORS



ASNU265
White 3mm Teflon Seal

PIEZO ADAPTER BOX
CHOICE OF THREE COLOURS
ALL THE ABOVE PARTS ARE PART OF THE KIT
SUPPLIED WITH THE ASNU PIEZO ADAPTER
BOX



ASNU124&125
PIEZO INJECTOR WIRING HARNESS



TECHNICAL NOTES:

FOR TECHNICAL ASSISTANCE, PLEASE CALL:
UK (44) (0)208 420 4494 OR FAX: UK (44) (0)208 420 4495 OR EMAIL: asnu.sales@asnu.com

PIEZO INJECTORS



**BOSCH
PIEZO GDI**
MERCEDES
Gasoline Direct
Injection



ASNU 122
FUEL RAIL FOR
SIEMANS PIEZO INJECTORS



ASNU 123
INJECTOR TO FUEL RAIL
COUPLING FOR
BOSCH PIEZO INJECTORS



ASNU265
White 3mm Teflon Seal

PIEZO ADAPTER BOX
CHOICE OF THREE COLOURS
ALL THE ABOVE PARTS ARE PART OF THE KIT
SUPPLIED WITH THE ASNU PIEZO ADAPTER
BOX



ASNU124&125
PIEZO INJECTOR WIRING HARNESS



TECHNICAL NOTES:

FOR TECHNICAL ASSISTANCE, PLEASE CALL:
UK (44) (0)208 420 4494 OR FAX: UK (44) (0)208 420 4495 OR EMAIL: asnu.sales@asnu.com



The Classic GDI

Injector Diagnostic
Testing & Servicing System

The ASNU Classic GDI

A complete system for the latest generation fuel injection

What is GDI?

GDI is an abbreviation for Gasoline Direct Injection, a process where the fuel is injected directly in to the combustion chamber. There are many variation of this process, with manufacturers preferring their own abbreviation of the system, here are some of the ones currently in use:

FSI = VW Audi (Fuel Stratified Injection)

SCI = Ford (Smart Charge injection)

IDE = Renault (Injection Direct Essence)

JTS = Alfa Romeo (Jet Thrust Stoichiometric)

SIDI = Holden (Spark Ignition Direct Injection)

HPI = BMW (High Precision Injection)

HPDI = Porsche (High Pressure Direct Injection)

Ecotec = GM, Vauxhall, Opel

CGI = Mercedes Benz (Charged Gasoline Injection)

DISI = Ford/Mazda (Direct-Injection-Spark-Ignition)

GDI = Mitsubishi Peugeot Citroën, Hyundai, Volvo, (Gasoline Direct Injection)



The GDI Combustion Chamber



Bosch GDI Injectors
&
Fuel Pump

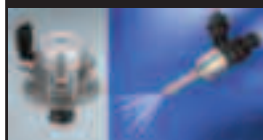

On a GDI system, the fuel is injected directly in to the combustion chamber at a much higher pressure than manifold systems, up to 200 bar.

These systems now require fuel pumps and injectors made of stainless steel and must be capable of performing at a much higher specification than ones seen on previous manifold injection systems.

Both designed to deliver very precise quantities of fuel at extremely high pressures and in short periods of time, in some cases for fractions of a milli second.

To control these systems, the ECU is also of a higher specification and required to supply a higher current of up to 90v on some systems.

There are many manufacturers of this type of system, but Robert Bosch are recognised as one of the leaders in the development of the GDI Technology.

The GDI System has two running modes: Stratified & Homogeneous.

Stratified Charge Running Mode.

This mode is the economical combustion cycle, in some systems, the Air to Fuel ratio can be as high as 65 to 1.

In this mode the injector delivers a minimum amount of fuel in to the combustion chamber, just before the piston reaches the top and before the plug fires. This mode is used at idle and light throttle settings when the car is driven slowly.

Homogeneous Running Mode.

This mode is what would be called a normal combustion cycle, with an Air to Fuel ratio of 25 to 1.

In this mode the injector delivers a normal amount of fuel in to the combustion chamber. This gives the engine the required performance as the car goes faster.

The Engine Management System determines when the system needs to switch between the Stratified Charge Mode and the Homogeneous Running Mode.



Stratified Mode



Homogeneous Mode

Spray pattern & flow rate analysis

The ASNU system has been designed for comparing injector against injector at a safe operating level and is suitable for use by apprentice level mechanics to Master level engineers.

To enable a safe and easy examination of the injector's performance, the ASNU system runs the injectors at a lower and safer operating fuel pressure of up to a maximum of 10 bar. On a vehicle fitted with a GDI system the fuel pressure will operate at a potentially dangerously high level for the inexperienced, reaching anywhere between 75 bar up to 200 bar on some systems.

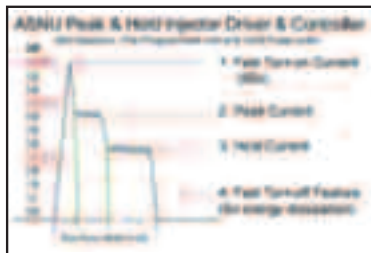

The Engine Management System of a GDI is designed to open the injectors for short micro second durations, with a maximum opening duration of only 5 milliseconds, any visual analysis of the injectors spray pattern could be both difficult and dangerous. When mounted on the ASNU Classic GDI, the injectors are being supplied with the correct peak and hold currents and firing in sequential mode simulating those of the vehicles ECU.

The ASNU allows the user to safely examine the injectors Spray pattern in greater detail for any discrepancies in the fuel distribution and atomisation.



In some operating modes, the ASNU system opens the injectors for a much longer duration, thus exaggerating the spray pattern and making it easier to examine the spray's performance.

GDI Injectors & Fuel Trims

The Distribution and Atomisation on a GDI Injector are critical to maintaining the correct Performance, Fuel Economy and Exhaust Emissions. They are now even more important than the quantity of fuel being delivered by the injector. The latest adaptive Engine Management Systems have a Short and Long Term Fuel Trim adjustment, adjusting the fuel delivery as compensation for any discrepancies in the C.O emissions. An adjustment of up to 15% can be made to the fuel delivery of each injector on some systems, but as there are number of measurements that contribute to the Fuel Trim Adjustment, these measurements cannot adjust or correctly compensate for poor Fuel Distribution and Atomisation.

FUEL TRIM ADJUSTMENTS ARE NOT CORRECTING THE CAUSE THE PROBLEM, ONLY COMPENSATING FOR IT. DON'T FIND THE PROBLEM, FIND THE CAUSE OF THE PROBLEM



NONE OF THE CURRENT ENGINE MANAGEMENT SYSTEMS CAN MEASURE OR COMPENSATE FOR ARE THE INJECTORS FUEL DISTRIBUTION AND ATOMISATION

A selection of GDI Injectors with discrepancies in the Distribution and Atomisation of the spray patterns

The ASNU system allows the user to visually examine the injectors on an individual cycle or in sequential mode, where they can compare the injectors performance under a range of simulated Millisecond & RPM driving cycles already programmed in to the ASNU system. The injectors can be operated at various RPM & Milli Second settings, restricted only by the number of injectors being tested in the sequential testing operation.

The ASNU Classic GDI

Technical Specifications

The ASNU Classic Features

- Backlit Viewing Window
- Multi Language Selection
- Digital Operational Display
- Membrane Key Pad
- Wide Range of Functions
- Injector Shot Counter Display
- Injector Shot Timer Display
- Duty Cycle Display
- Up to 10,000 RPM
- Manual & Automatic Cleaning Cycles
- Suitable for Injected Motorcycles
- Suitable for Injected Marine Engines
- Suitable for LPG Injection
- For use on EVERY type of Manifold Injector

Local ASNU Distributor:

Specifications

Input Voltage:

96v – 265v

Dimensions & Weight:

L W H Weight

55 x 45 x 70 cm 30Klg

Additional GDI Features

- Suitable For All Types GDI Injectors
- USB Computer interface for user setting of Peak & Hold Currents & mS pulse widths and RPM
- Peak & Hold Current Control with ECU matched current settings
- Tests Up To 8 GDI/FSI Injectors at one time
- Static and Dynamic operation
- Sequential Injector Firing Operation for GDI injectors
- Fast injector turn on and turn off circuits giving more repeatable results
- Single Injector Selection During Multi Injector Operation
- Suitable for Standard Manifold Injectors with Sequential or Simultaneous firing option
- 18 Various M/S & RPM Test Settings
- Simulates on-car Spray Patterns & Flow Rates
- Injector Inductance Test - Checking Injector Electro Magnetic Circuit
- Injector Leak Down Test
- Ultrasonic Injector Cleaning Cycle
- 12 Language Selection Screen
- Lbs per hour to Milliliters calculator
- Easy to Read LCD Screen
- Membrane Key Pad

ASNU Corporation Europe Ltd

65 – 67 Glencoe Road, Bushey, Herts. WD23 3DP. England.

Tel: +44 208 420 4494 Fax: +44 208 420 4495

Web Site: www.asnu.com E-Mail: asnu-sales@asnu.com

ACCESSORIES & SPARES



ASNU41C
BIO-CLEAN ULTRASONIC
CLEANING FLUID
CONCENTRATE
1 LITER BOTTLE



ASNU41
BIO-CLEAN ULTRASONIC
CLEANING FLUID PRE-MIX
5 LITER BOTTLE



ASNU42
FLOW-RITE
CALIBRATION FLUID
1 GALLON



ASNU44
ADAPTER COUPLING
EXTRA LONG EXTERNAL
FOR SHORT INJECTORS



ASNU47
8MM FEMALE
ADAPTER COUPLING
FOR 8MM MALE COLD START
INJECTOR



ASNU48
10MM MALE
ADAPTER COUPLING
FOR 10MM FEMALE
COLD START INJECTOR



ASNU49
ADAPTER COUPLING
COLD START INJECTOR
HOSE TYPE (12-13MM)



ASNU50
10MM FEMALE
ADAPTER COUPLING
FOR 10MM MALE
COLD START INJECTOR

ACCESSORIES & SPARES



ASNU54
8MM MALE
ADAPTER COUPLING
FOR 10MM FEMALE
CIS (K-JET)



ASNU55
12MM FEMALE
ADAPTER COUPLING
FOR 12MM MALE
CIS (K-JET)



ASNU57
ADAPTER COUPLING
BOSCH, LUCAS, WEBER,
MARELLI, SIEMENS
TESTS INJECTORS
WITHOUT REMOVING
INLET FILTER



ASNU58
ADAPTER COUPLING
TESTS MULTI-PORT
INJECTORS WITH FUEL
HOSE INSTALLED



ASNU59
ADAPTER COUPLING
SLIM TYPE DENSO
TESTS INJECTORS
WITHOUT REMOVING
INLET FILTER



ASNU68
ADAPTER COUPLING KIT
MERCURY MARINE
OPTIMAX GDI INJECTOR



ASNU70
UNIVERSAL HARNESS
CONNECTS MOST
MULTI-PORT INJECTORS



ASNU71
ADAPTER BLOCK
GM TBI MAXI
WITH CUSTOM HARNESS
(single block - use ASNU101 for
double block)



ASNU72
ADAPTER BLOCK
GM TBI MULTEC
WITH CUSTOM HARNESS
(single block - use ASNU115
for Quad Block)

ACCESSORIES & SPARES

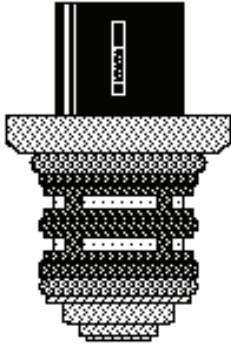

ASNU73
ADAPTER BLOCK
FORD CFI - HOLLEY SPI
CHRYSLER & BOSCH
WITH CUSTOM HARNESS
(single block - use
ASNU113 for twin block)



ASNU76
ADAPTER BLOCK
BOSCH SPI
(Tests 1 injector)

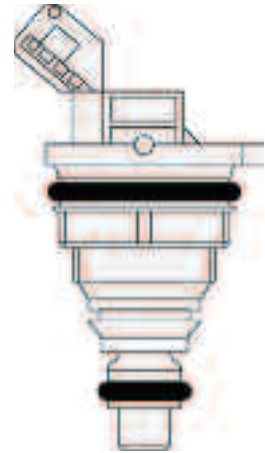

ASNU78
ADAPTER BLOCK
FORD ZETA MPI/SPI
(BOSCH / WEBER /
SIEMENS / DENSO)
(Tests 4 injectors)



ASNU81
CUSTOM NYLON COVER
FOR ASNU MACHINE

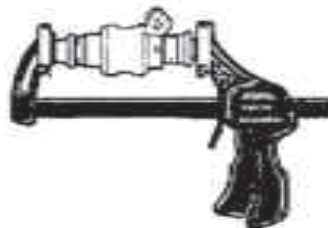

ASNU84
PINTLE CAP & FILTER
ASSEMBLY TOOL



ASNU85
BOSCH EV1 PINTLE CAP
REMOVAL TOOL
GUN TYPE

ACCESSORIES & SPARES



ASNU86
FILTER BASKET
REMOVAL TOOL

NEWLY RE-TOOLED ITEM!



ASNU87
CUSTOM FIT
RUBBER BENCH MAT



ASNU89
WEBER / SIEMENS
TOP FEED MULTIPOINT
"MINI PECO INJECTOR"
ADAPTER PLATE
twin pack



ASNU92
INJECTOR SERVICE
REPORT PAD
50 SELF CARBON
(ENGLISH ONLY)



ASNU97
SIDE FEED INJECTOR
CLEANING TRAY
(SHALLOW)



ASNU99
Mini Peco S/S Injector Cleaning Tray

ACCESSORIES & SPARES



ASNU101
ADAPTER BLOCK
GM TBI MAXI
(Tests 2 injectors, includes
custom harness)

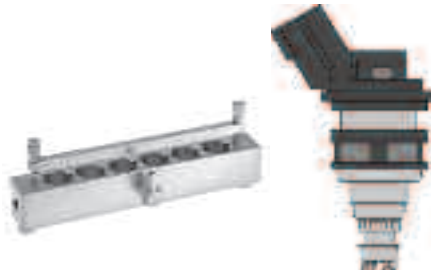

ASNU103
ADAPTER BLOCK
NISSAN JECS
(Tests 6 injectors)



ASNU104
ADAPTER BLOCK
TOYOTA JECS MPI
PREVIA / TARAGO
(Tests 6 injectors)



ASNU105
ADAPTER BLOCK
NISSAN PATHFINDER /
NAVARA
(Tests 4 injectors)

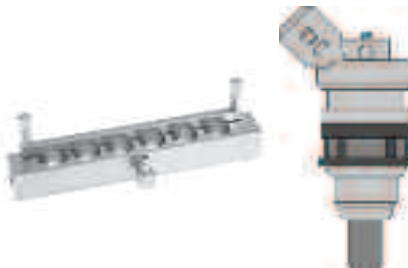

ASNU106
ADAPTER BLOCK
NISSAN / SUBARU SPI
(Tests 6 injectors)



ASNU107
ADAPTER BLOCK
MAZDA DENSO
(Tests 6 injectors)



ASNU108
ADAPTER KIT
GM VORTEC 4.3L
EARLY VERSION
(Tests complete assembly)



ASNU109
ADAPTER KIT
GM VORTEC 4.3L & 5.7L
LATE VERSION
(Includes ASNU109H
Harness & Cleaning Tray)

ACCESSORIES & SPARES

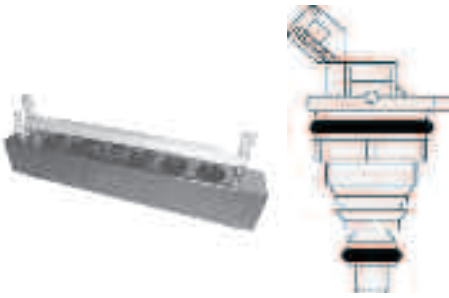

ASNU110
ADAPTER BLOCK
FORD ZETA / SIEMENS
CHRYSLER 3.5L
(Tests 6 injectors)



ASNU112
ADAPTER BLOCK
NISSAN MICRA JECS
(Tests 4 injectors)



ASNU114
CUSTOM HARNESS
ROUND PIN TYPE
CONNECTORS
(Tests up to 8 injectors)

NEW ITEM!

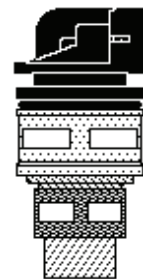

ASNU115
ADAPTER BLOCK GM TBI MULTEC 700
(Tests 4 injectors, includes custom harness)

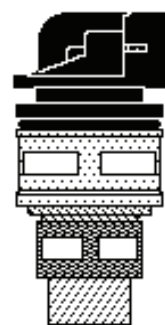

ASNU116
CUSTOM HARNESS FOR 8 DELPHI
INJECTORS & 8 ROCHESTER TBI 700
MULTEC INJECTORS

ACCESSORIES & SPARES



ASNU150
FLOW DISPLAY
WINDOW



ASNU151
CALIBRATION FLUID
TANK COVER



ASNU152
GLASS MEASURING
CYLINDER - MM



ASNU153
ULTRASONIC BATH
INJECTOR CRADLE



ASNU154
CALIBRATION FLUID
IN-LINE FILTER



ASNU155
FUEL PUMP
FILTER



ASNU156
BRASS FUEL TEST
RAIL ASSEMBLY
MULTIPOINT INJECTORS
(includes 8 capping off nuts,
replacement model includes
extension bolts for long
GDI injectors)



ASNU266
Seal Fitting Cone
ASNU266T
Seal Compression Tool
For use with ASNU 265/265A as shown



ASNU258
GM/Hyundai/Kia Adapter

ACCESSORIES & SPARES



**ASNU708
BACKLIGHT KIT**
(Add light to view Spray Patterns on
older style ASNU machines)

MISC. O-RINGS



ASNU52
Lower for
ASNU51 Cou-
pling



ASNU53
Upper for ASNU51,
fits ASNU156 Test Rail
& ASNU54 K-Jet Coupling



ASNU157
Fits Capping off
nut ASNU58



ASNU71A
Fits Adapter Blocks
ASNU71
& ASNU101



ASNU404
O-Ring
Measuring Cylinder
Couplings - Upper



ASNU405
O-Ring
Measuring Cylinder
Couplings - Lower

ACCESSORIES & SPARES

GDI ACCESSORIES, TOOLS & SPARES



ASNU GDI ADAPTER BOX

UPGRADE EXISTING ASNU CLASSIC MACHINES TO GDI TESTING & CLEANING CAPABILITY

GDI Adapter Box Features:

- Suitable For All Types GDI Injectors
- USB Computer interface for user setting of pulse widths and currents
 - Peak & Hold Current Control with ECU matched current settings
 - Tests Up To 8 GDI/FSI Injectors at one time
 - Static and Dynamic operation
 - Sequential Injector Firing Operation for GDI injectors
- Fast injector turn on and turn off circuits giving more repeatable results
 - Single Injector Selection During Multi Injector Operation
- Suitable for Standard Manifold Injectors with Sequential or Simultaneous firing option
 - 18 Various M/S & RPM Test Settings
 - Simulates on-car Spray Patterns & Flow Rates
- Injector Inductance Test - Checking Injector Electro Magnetic Circuit
 - Injector Leak Down Test
 - Ultrasonic Injector Cleaning Cycle
 - 12 Language Selection Screen
 - Lbs per hour to Milliliters calculator
 - Easy to Read LCD Screen
 - Membrane Key Pad
- Updates early model ASNU Machine To Latest Specification
 - Use with Any ASNU System
- Could be used with Non ASNU systems

PIEZO

PETROL/GASOLINE



PIEZO GDI ADAPTER BOX

ASNU PIEZO

Diagnosing Injector Performance

Piezo injector is the current system of choice of major executive vehicle manufacturers. Piezo injectors can respond so quickly that they can allow the vehicle to run at incredible air/fuel ratios of up to 60:1 in some engines. Compared to standard vehicles running at 14:1 air/fuel ratios, this means the minimum amount of fuel is used and the exhaust emissions are virtually non-existent, while still maintaining excellent drivability and performance. As you can imagine, the performance of these injections is critical, maintenance should not be an option, it should be mandatory.

How often do you check your Piezo injectors?

Piezo injections offer performance, driveability, economy and the ultimate in exhaust emissions.



How do
you
test your
Piezo injectors?

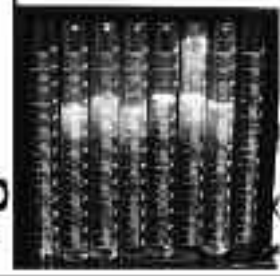

Equipment Included in Piezo Adapter Box



Bosch Fuel Rail



Siemens Fuel Rail



Injector Harness



Bosch Coupling (QTY 6)



Siemens Coupling (QTY 6)



Connection Harness

Special Features

In conjunction with a world leading vehicle manufacturer, ASNU have created this purpose built adapter box.

- ◆ Easy to use test functions using the latest Piezo technology
- ◆ Easy connections to Classic GDI Machine or GDI adapter Box.
- ◆ Universal fittings for Piezo type injectors
- ◆ Dimensions: 300mm x 190mm x 220mm in a robust metal casing

ASNUTM = *good as new...*

ASNU Corporation Europe LTD,
65-67 Glencoe Road, Bushey,
Herts. WD23 3DP England.
Tel: (44) 208 420 4494
Fax: (44) 208 420 4495
www.asnu.com
email:asnusales@asnu.com

DISTRIBUTOR



ACCESSORIES & SPARES

GDI ACCESSORIES, TOOLS & SPARES ASNU GDI INJECTOR EXTRACTION KIT ASNU 266K



An essential welcome addition to the tool range of any technician involved with the removal and re-installing of tight fitting or inaccessible GDI/FSI injectors. The kit contains a 2 part extraction/installation tool, an adjustable puller & slide hammer, fuel rail injector refitting tool, head cleaning brush and an injector lower seal compression fitting set.



2 PART
EXTRACTION
TOOL

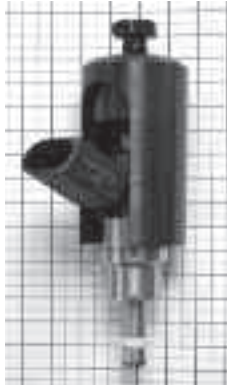

Adjustable
Puller &
Slide Hammer



FUEL RAIL INJECTOR
REFITTING TOOL



Extraction Tool used with Slide Hammer





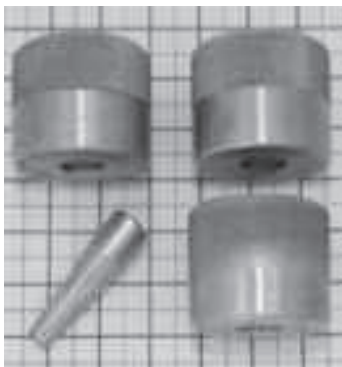

HEAD CLEANING BRUSH



INJECTOR LOWER
SEAL COMPRES-
SION FITTING SET



ACCESSORIES & SPARES

APPLICATIONS				
Gasoline	Gasoline	Gasoline Designed for GDI	Gasoline & Methanol	Gasoline
Material & Filter Length Including Brass Ring				
Plastic 6mm	Plastic 8mm	Plastic 10mm	Wire 10mm	Plastic 13mm
				
Brass Ring Size				
6mm	5.5mm	6mm	6mm	6.5mm
ASNU PART NUMBER				
ASNU 02	ASNU 02A	ASNU 03	ASNU 03W	ASNU 04



WARRANTY DISCLAIMER

Although the information contained within this catalog is believed to be reliable, no warranty (expressed or implied) can be made as to its accuracy or completeness, nor is any responsibility assumed by the seller of the ASNU DIAGNOSTIC TEST BENCH & ULTRASONIC FUEL INJECTOR CLEANER or anyone connected with it for loss or damages suffered through reliance on any information contained in this catalog.

SPECIFICALLY, NO WARRANTY OF MERCHANTABILITY, FITNESS FOR A PARTICULAR PURPOSE OR ANY OTHER WARRANTY IS MADE OR TO BE IMPLIED WITH RESPECT TO THIS CATALOG AND ITS CONTENTS. IN NO EVENT WILL SELLER BE LIABLE FOR ANY DAMAGES, DIRECT OR INDIRECT, CONSEQUENTIAL OR COMPENSATORY, INCLUDING, WITHOUT LIMITATION, LOST PROFITS, FOR ANY REPRESENTATIONS, BREACHES OR DEFAULTS ARISING OUT OF THE USE OF THIS CATALOG.

Customer agrees to indemnify seller and hold it harmless against all claims and damages, including without limitation, reasonable attorney's fees arising from the use of this catalog, unless such claims or damages result from the infringement of any copyright or other proprietary right of any third party.

TECHNICAL INFORMATION

Due to the wide design variety of injectors between different manufacturers, we strive to maintain the information in this catalog up to date.

We welcome recommendations and comments regarding the ASNU machine functionality, maintenance, and pictures or samples of injectors that require study & adapter development that do not appear in this catalog.

Please e-mail: asnu.sales@asnu.com

Please visit our web site: www.asnu.com

????????????

Because a booklet has to be in multiples of 4, I've added one blank page.



ASNU Corporation Europe Ltd

Phone +44 (0) 208 420 4494 Fax +44 (0) 208 420 4495

e-mail: asnu.sales@asnu.com web site: www.asnu.com